



SALIMA FILALI
CRÉATRICE DE DÉCORS

The image displays several rectangular tiles from the Zellige collection, arranged in a grid. The central tile is a light green color with a repeating pattern of golden-brown, semi-circular shapes that resemble stylized sunbursts or fan-like motifs. To the left, a dark grey tile with a simple grid pattern is visible. Below the central tile, a white tile with a golden-brown geometric pattern is shown. At the bottom, a dark green tile with a complex, interlocking geometric pattern in golden-brown is visible. The tiles are set against a light background, and the lighting creates soft shadows, highlighting their texture and the precision of the patterns.

ZELLIGE COLLECTION

Salima Filali offers a collection of decors made in zellige to adorn your interiors and exteriors. From ethnic patterns to the most graphic shapes, the elegance of her creations lies in the design and technical know-how, but also in the possibility of customising each of them. Take part in the design of your own decor by selecting its colours, size and shape, so that it meets all your dreams.



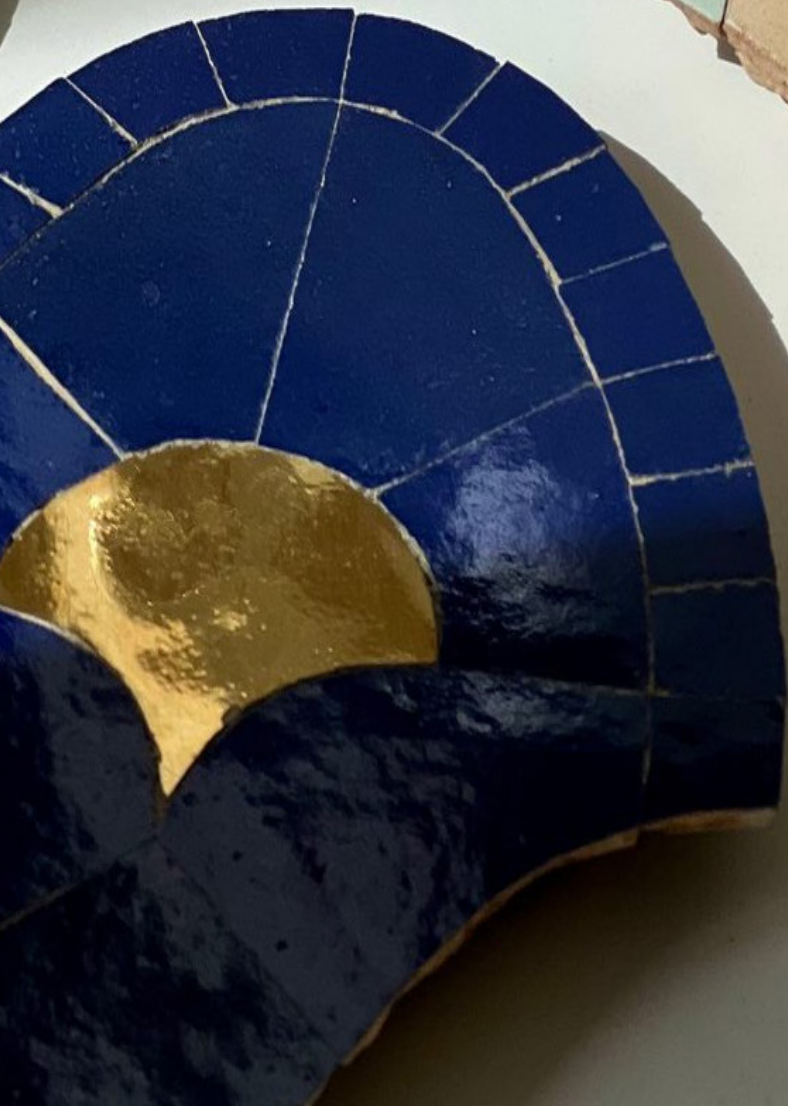

INDEX

- ◇ SALIMA FILALI
- ◇ IN THE MAKING
- ◇ EXCLUSIVE ZELLIGE COLLECTION
 - ◇ TUILE
 - ◇ ECRIN 02
 - ◇ PLUME 02
 - ◇ ECAILLE
 - ◇ ENVOL
 - ◇ TATAOUI 01
 - ◇ TOUAREG
 - ◇ PARTICULE
 - ◇ AURORE
 - ◇ ECLAT
 - ◇ DUNE
 - ◇ ZAHRA
- ◇ CLASSIC ZELLIGE COLLECTION
- ◇ ARTWORK
- ◇ COLORS



Enhance your interior with a set of zellige

Salima Filali revisits traditional aesthetics of the zellige art through her exceptional creations.

Zellige is a terracotta mosaic entirely handcrafted according to ancestral know-how.

Each piece is unique and enhanced by light.

An authentic and precious product, sublimated by Salima's creations through sophisticated and timeless decorations.

«I wish to invite this material on our walls like a graphic work. Zellige as art and witness to know-how.»

«My pieces are an expression of my creativity, and are enhanced by ancestral know-how. I want to honour our heritage, convey an emotion, arouse curiosity, appeal.»

SALIMA.



IN THE MAKING

Where does the zellige come from?

The zellige is a traditional art of Morocco. It belongs to the family of traditional Mediterranean ceramics. It is an ancestral art that dates from the 10th century and is passed on from generation to generation.

The basis of zellige, and the creation of tesserae, is made from clay. The quality of this raw material will directly impact the result of our zellige. That is why we select products from the region of Fez.

The clay quarries north of the city allow us to extract a white clay with porous properties that give the zellige a great strength and mechanical properties suitable for the hammering.

The zellige of Fez

If we work with artisans of Fez, it is not by chance. Not only does the quality of the raw materials make it a quality zellige, but the craftsmen are recognized for their great expertise.

Much more than a cultural identity, it is a real know-how. And this age-old profession truly anchored in the city of Fez, is a real heritage.

The zellige of Fez has been registered with the World Intellectual Property Organization on behalf of Morocco. Its classification by UNESCO as a world intangible heritage would be a real consecration

For its part, the Ministry of Crafts of Morocco has created the label «Zellige of Fez». This recognition demonstrates the quality of this art, but also of the products resulting from this craft.

And we are proud to work with these men and women, to perpetuate this tradition and offer you all the richness of the Moroccan mosaic.



EXCLUSIVE COLLECTION

Designed by Salima Filali

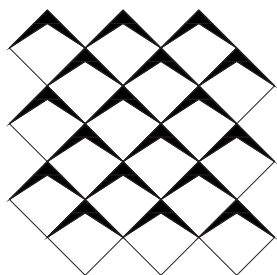

TUILE
Walls

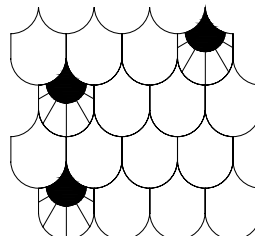

PLUME 01
Walls

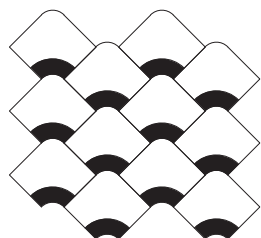

AURORE
Walls

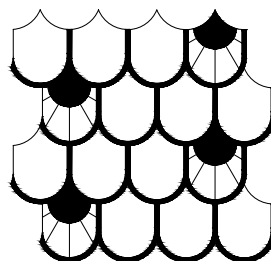

PLUME 02
Walls

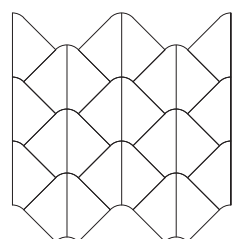

DUNE
Walls - floors

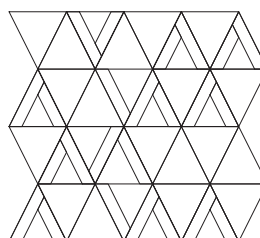

TOUAREG
Walls - floors

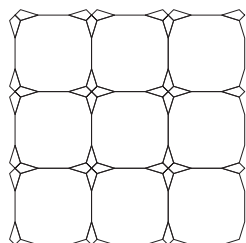

ZAHRA
Walls - floors

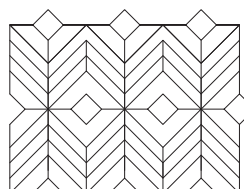

ETHNIE
Walls - floors

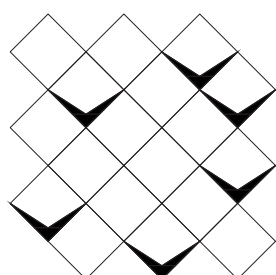

ENVOL
Walls

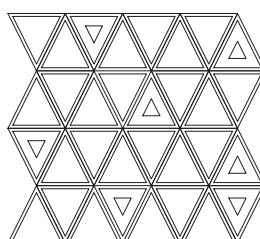

PARTICULE
Walls

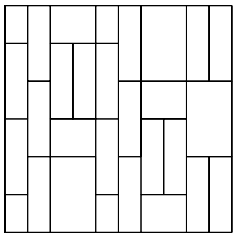

OPUS
Walls - floors

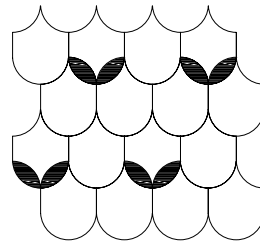

PLUME 03
Walls

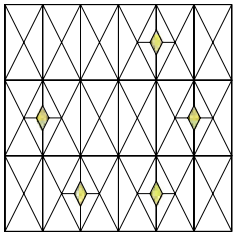

ECRIN 02
Walls - floors

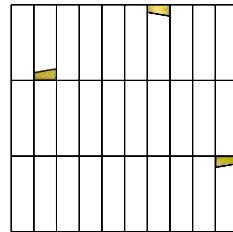

ECLAT 01
Walls -floors

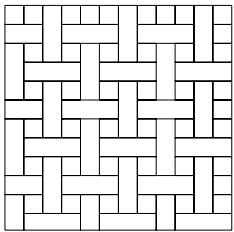

TRESSAGE
Walls - floors

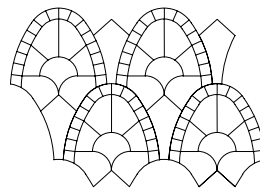

ECAILLE
Walls

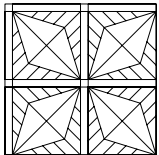

TATAOUI 01
Walls

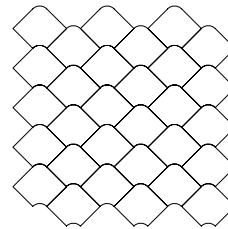

DUNE 02
Walls - floors

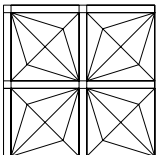

TATAOUI
Without chiselled pieces
Walls - floors

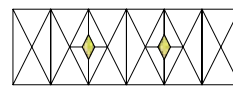

ECRIN 02
Walls -floors

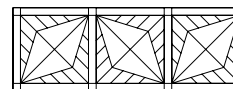

TATAOUI
Walls

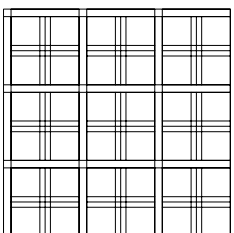

TARTAN
Walls

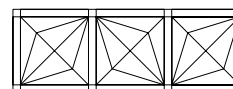

TATAOUI
Without chiselled pieces
Walls - floors

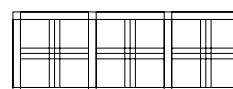

TARTAN
Walls

TUILE

«From the rooftops, in the heart of the Fez medina, I observe the tiles of Africa's oldest university. A beautiful graphic design of shadows created by a puzzle of tiles.»

Tuile design replicates this intertwining through an optical illusion that reveals depth, made possible by a play of shades and texture.

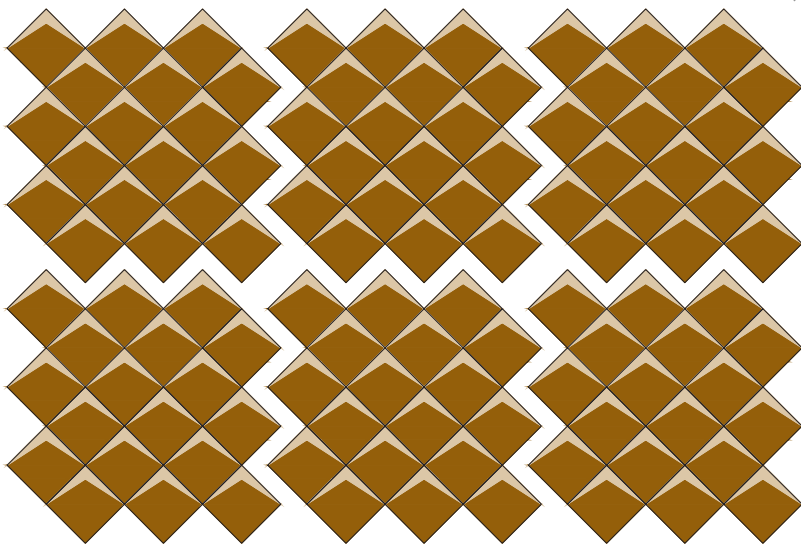
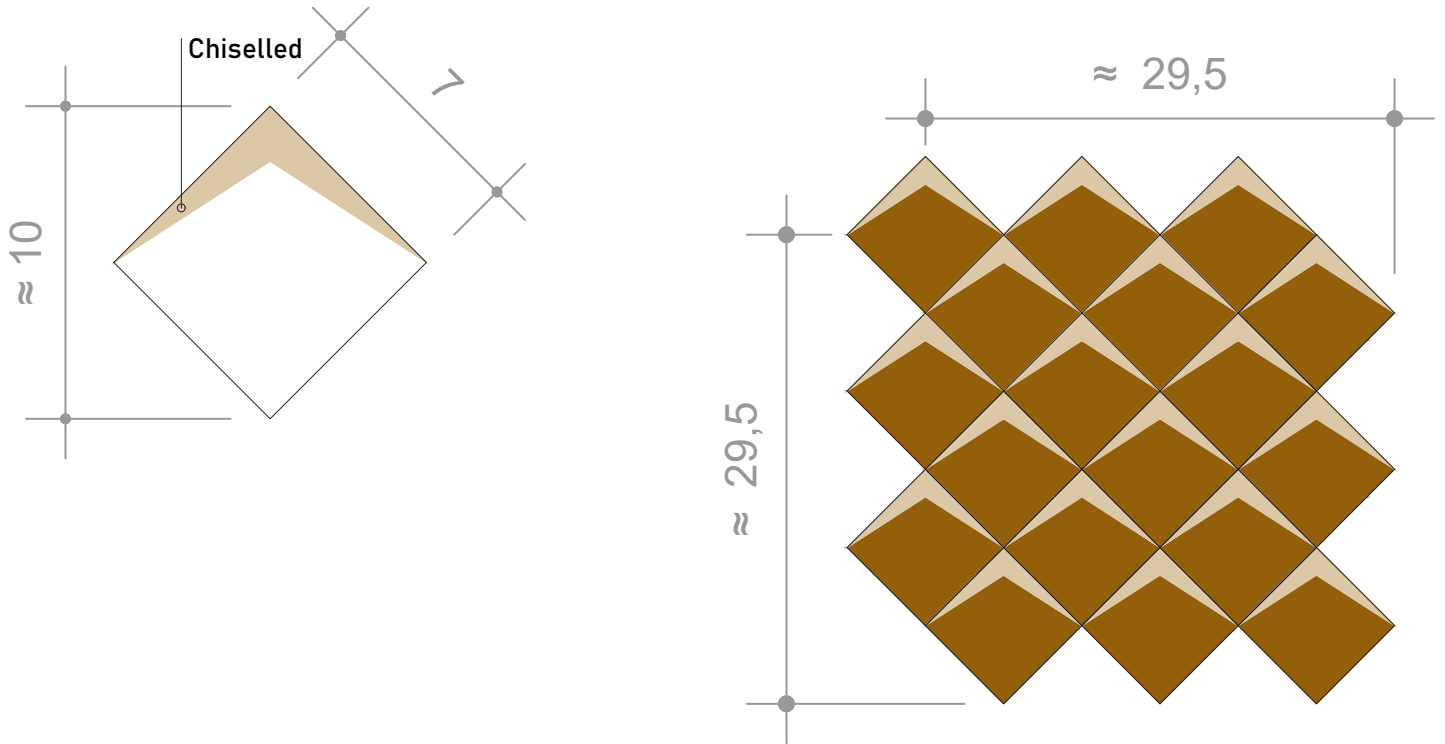

Pre-assembled and sealed plates

Suitability	walls, kitchen, bathroom, shower...
Size plate	≈ 30x30cm 11x11"
Thickness	12-14 mm 1/2 inch approx.
Number of pieces	216/m ² 20/sqft approx.
Number of plates	12/m ² 1=0.9 sqft
Colors	Colors chart

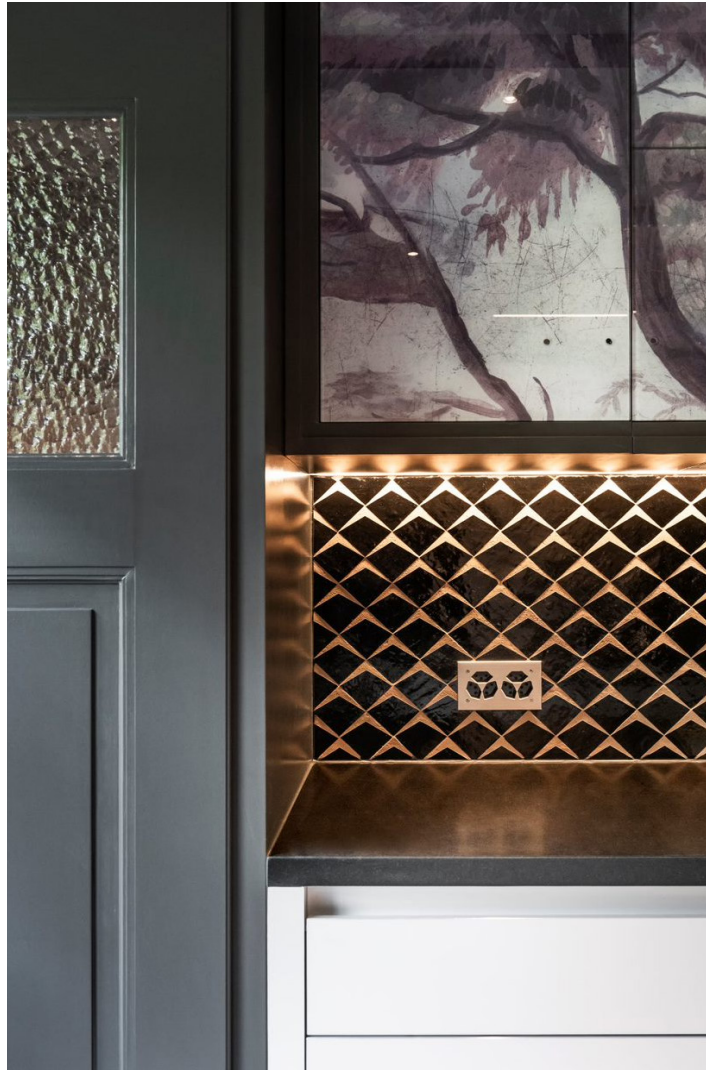

TUILE

Laying schemes

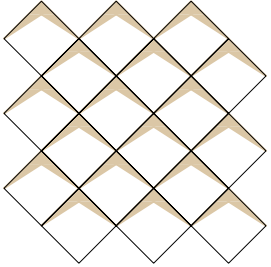

TUILE 1

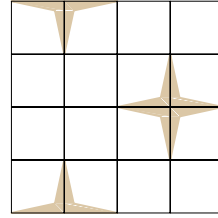

TUILE 6

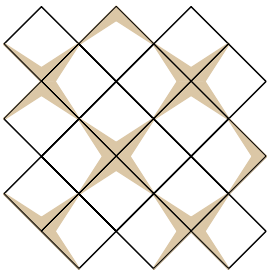

TUILE 2

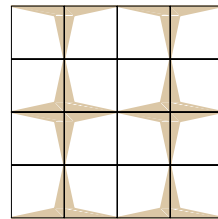

TUILE 7

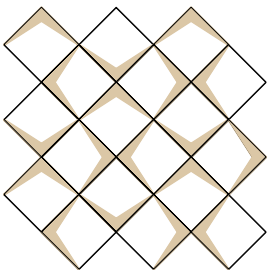

TUILE 3

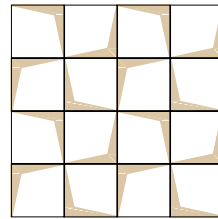

TUILE 8

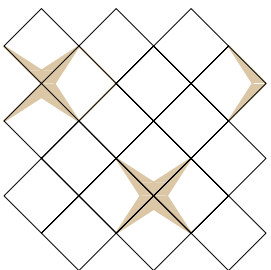

TUILE 4

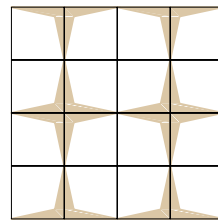

TUILE 9

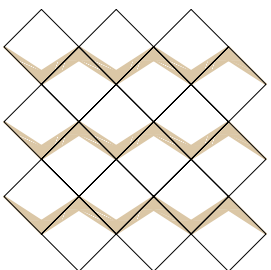

TUILE 5

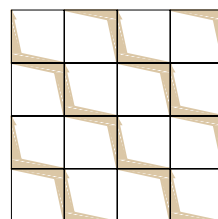

TUILE 10

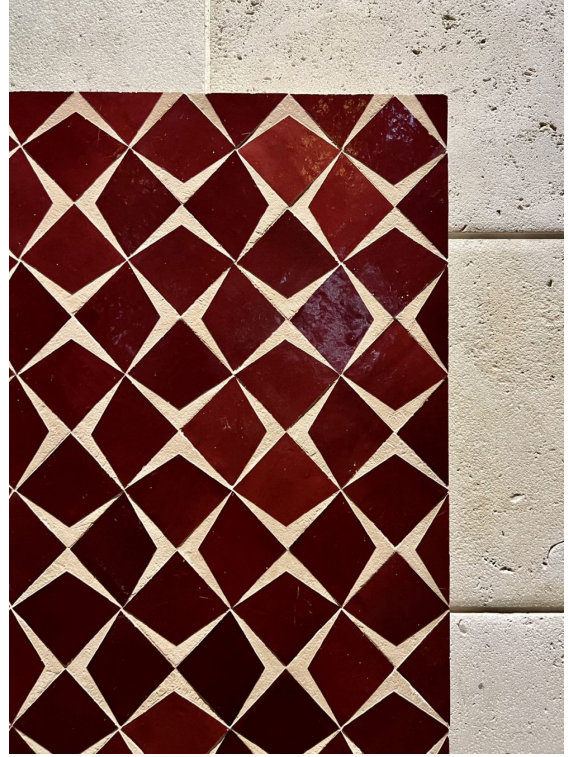





ECRIN 02

In this graphic creation, a few boxes hold in their heart of a precious small zellige. This creation highlights the finesse of the manual work in a complex, graphic and refined decor. The gold pieces are enamelled with 14 carat gold.

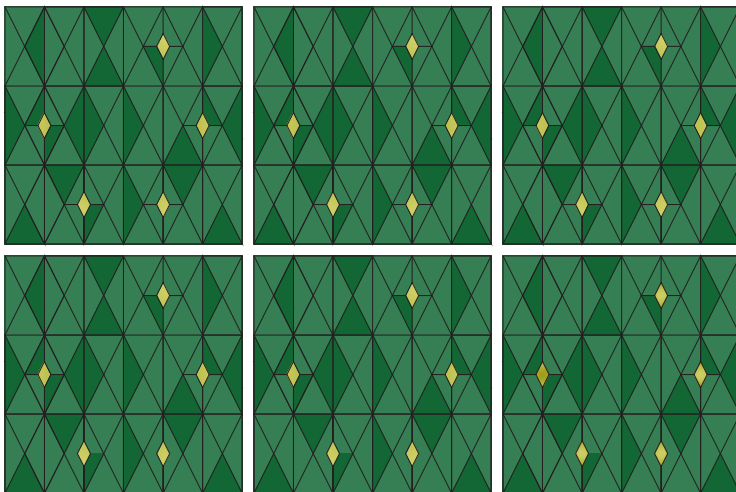
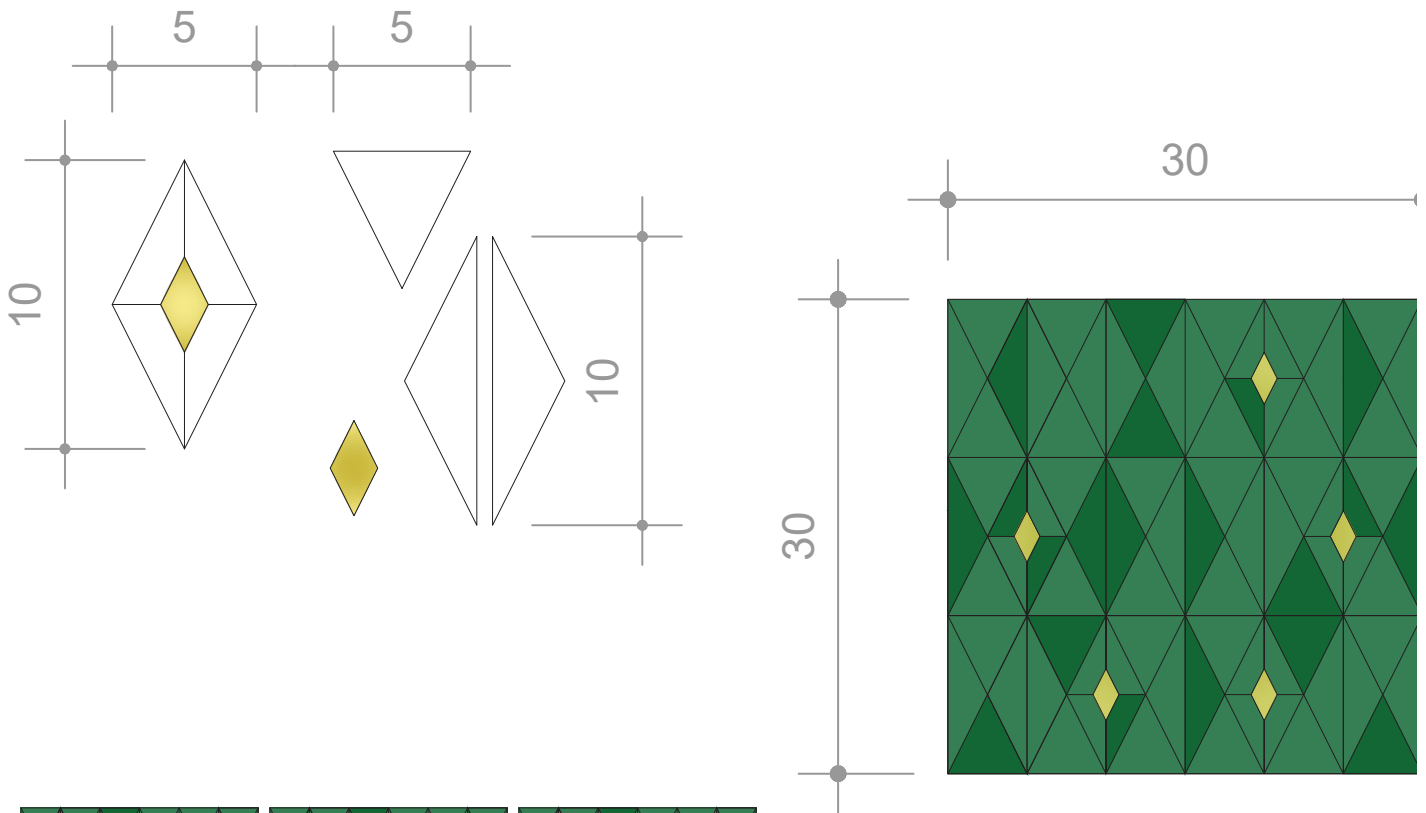

Pre-assembled and sealed plates

Suitability	walls, kitchen, bathroom, shower... without gold floors
Size plate	~ 30x30cm 11x11"
Thickness	12-14 mm 1/2 inch approx.
Number of pieces	957/m ² 87/sqft approx.
Number of gold pieces	55/m ² a 5/sqft
Number of plates	11/m ² 1/sqft
Colors	Colors chart



PLUME 02

This decor evokes a plumage finding its roots in the Art Deco movement. The enamelled and chiselled feathers represent a mix between tradition and modernity. Light embellishes textures and reveals a plumage with luxurious curves.

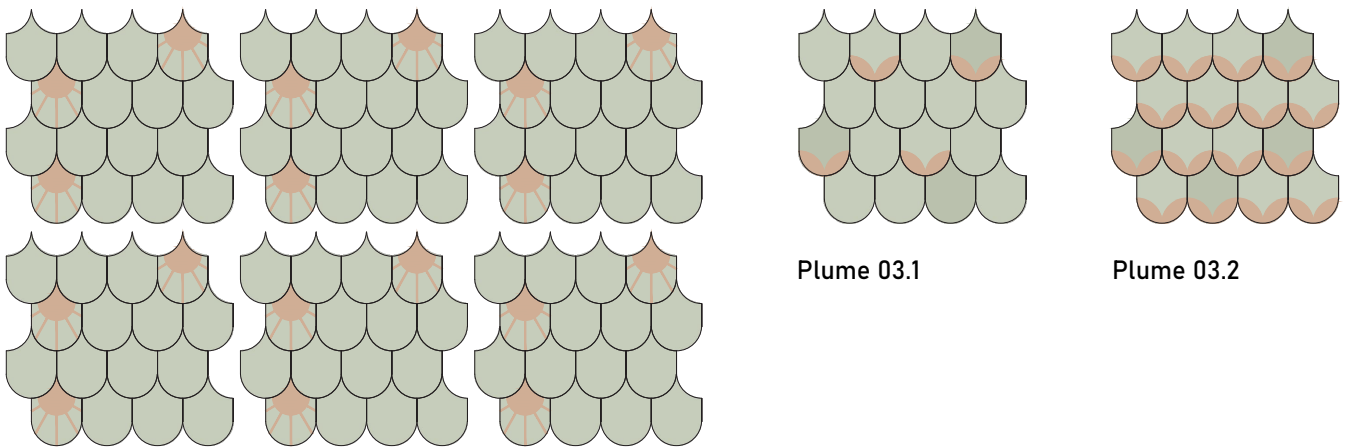
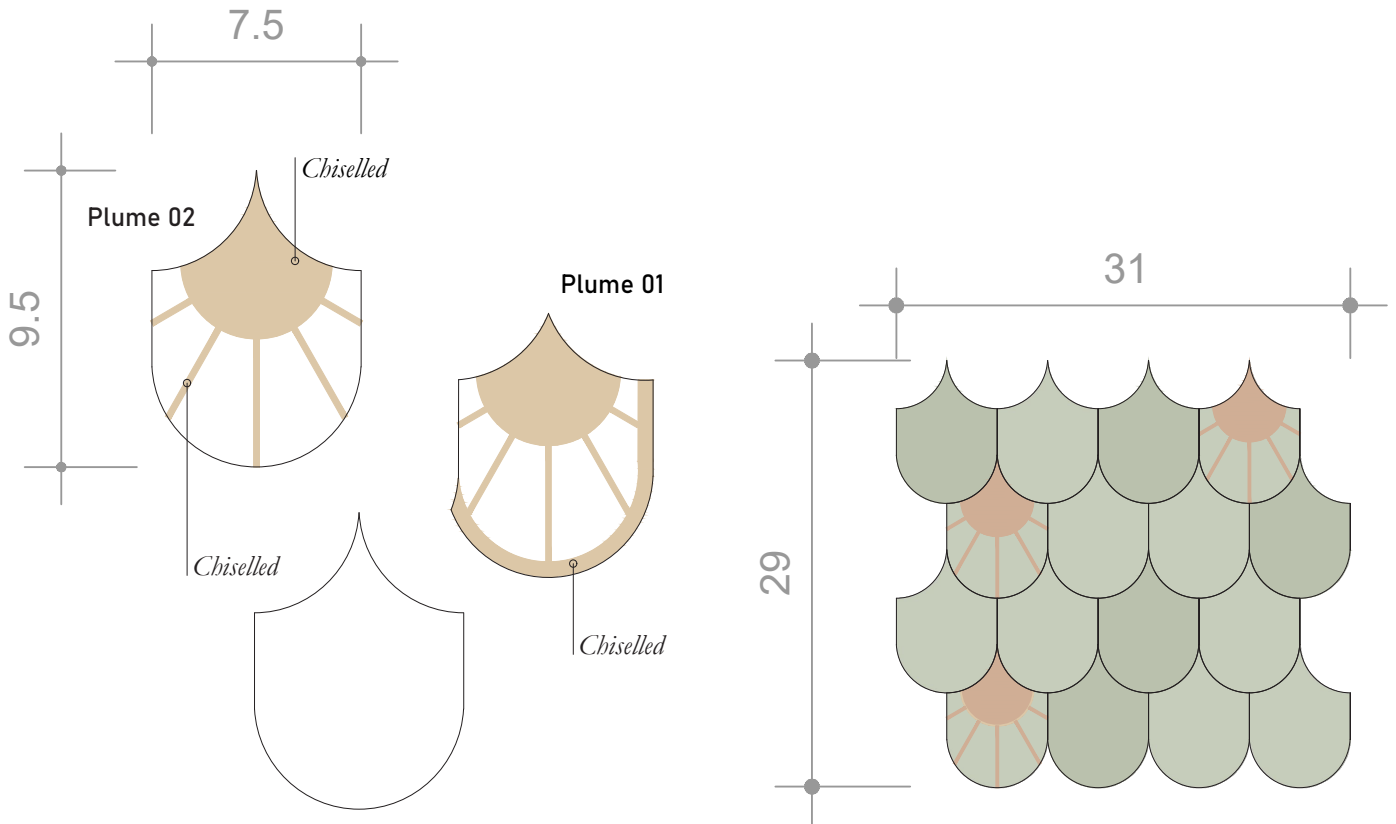

Pre-assembled and sealed plates

- Suitability** walls, kitchen, bathroom, shower...
without chiselled pieces: floors
- Size plate** ≈ 29x31cm | 11x12"
- Thickness** 12-14 mm | 1/2 inch approx.
- Number of pieces** 224/m² | 21/sqft approx.
- Number of plates** 14/m² | 1=0.78sqft
- Colors** Colors chart



Crédits photo: Luca Fascini - DVK architectes - Shower - Geneva





ECAILLE

This creation is composed of large scales of raw terracotta, each containing a small, glazed scale. Just like fish scales, each zellige scale captures and reflects light differently.

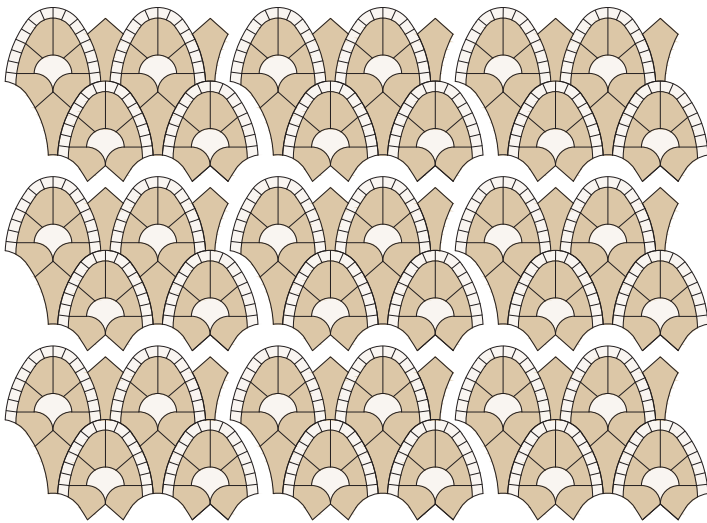
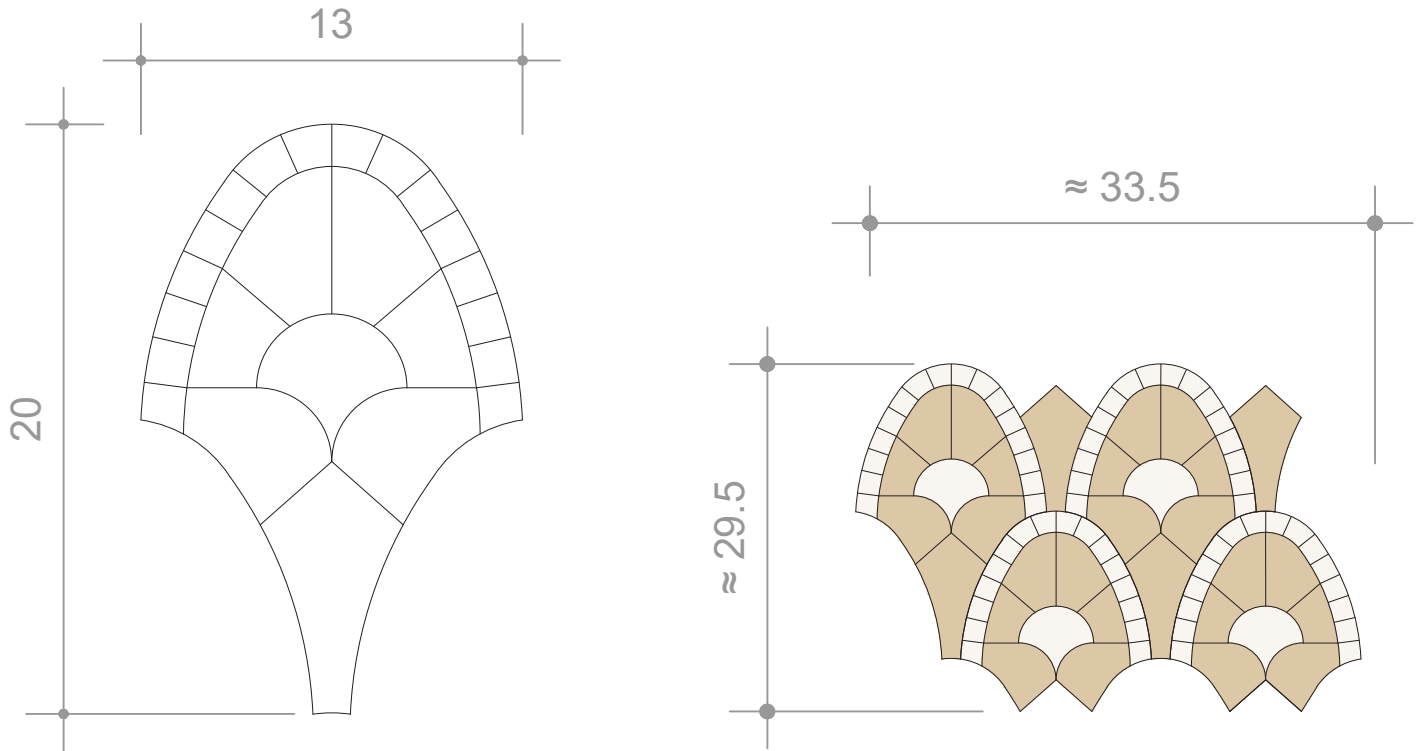

Pre-assembled and sealed plates

Suitability	walls, floors, kitchen, bathroom, ..
Size plate	≈ 23.5x33.5cm 9.2x13.2"
Thickness	12-14 mm 1/2 inch approx.
Number of pieces	1920/m ² 178/sqft approx.
Number of plates	20/m ² 1=0.5 sqft
Colors	Colors chart



Laura Gonzalez architecte - Institut du Monde Arabe Mima - Paris



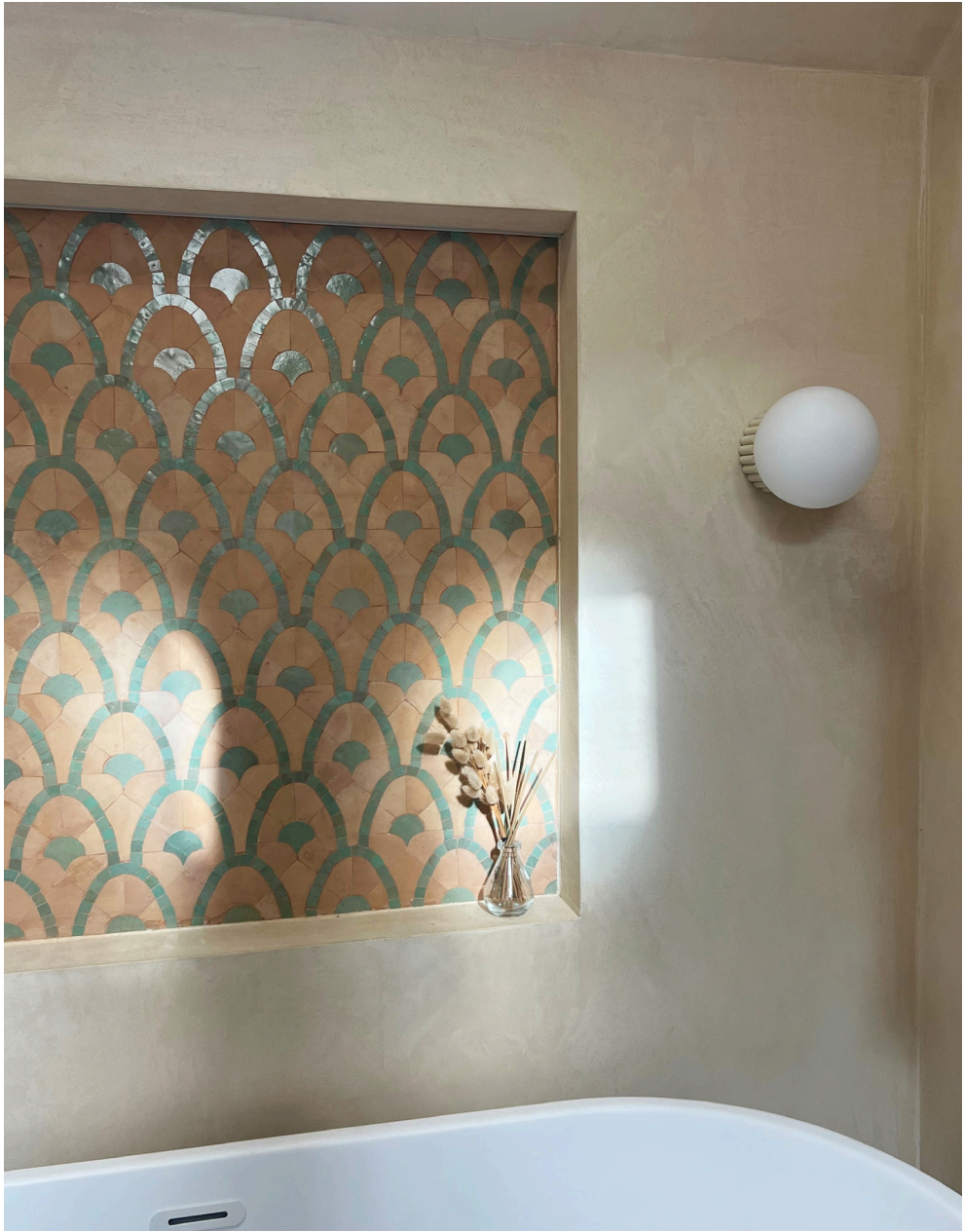

ENVOL

Like a flight in the sky, this creation is all in lightness. Envol is composed of enamelled zelliges and chiselled zelliges representing silhouettes of birds. A poetic and ever customizable creation.

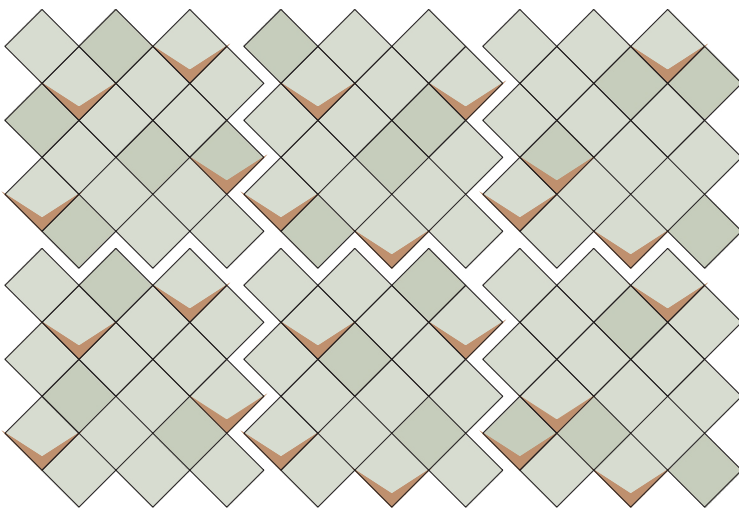
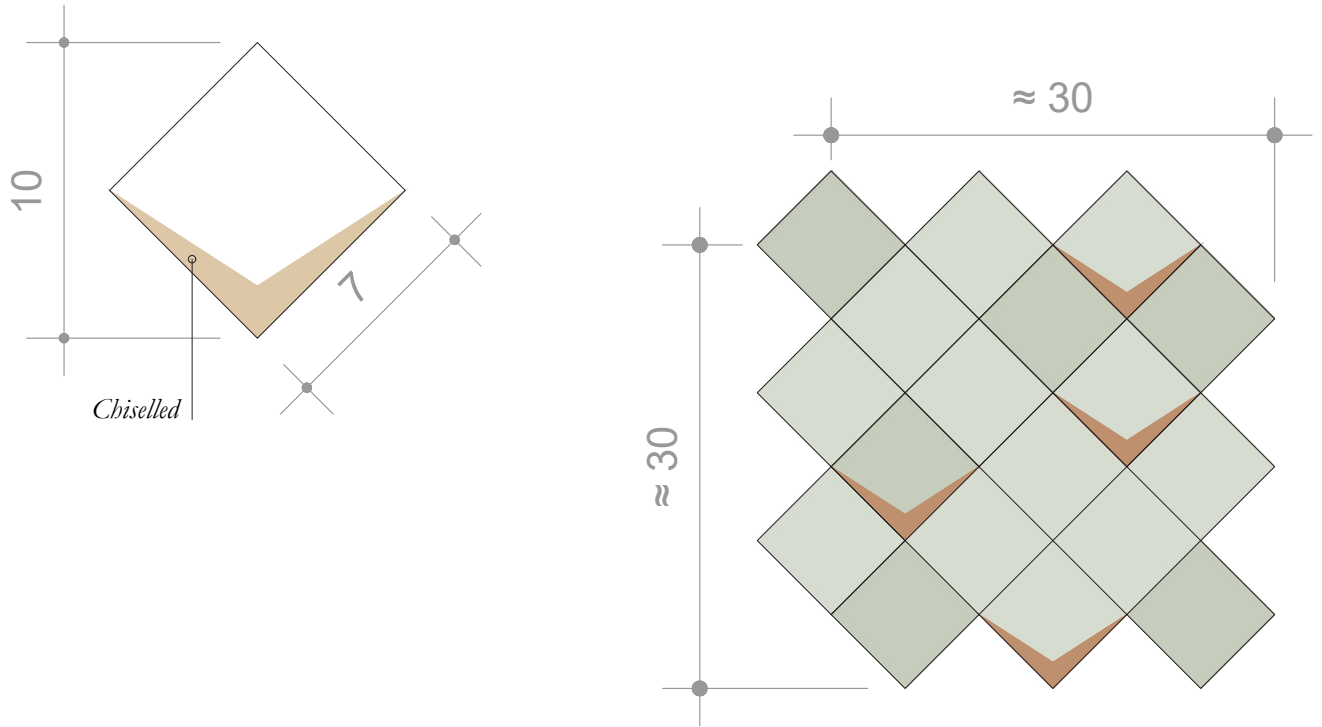

Pre-assembled and sealed plates

Suitability	walls, kitchen, bathroom, shower...
Size plate	≈ 30x30cm 11x11"
Thickness	12-14 mm 1/2 inch approx.
Number of pieces	216/m ² 20/sqft approx.
Number of chiselled pieces	48/m ² 4.5/sqft
Number of plates	12/m ² 1=0.9sqft.
Colors	Colors chart

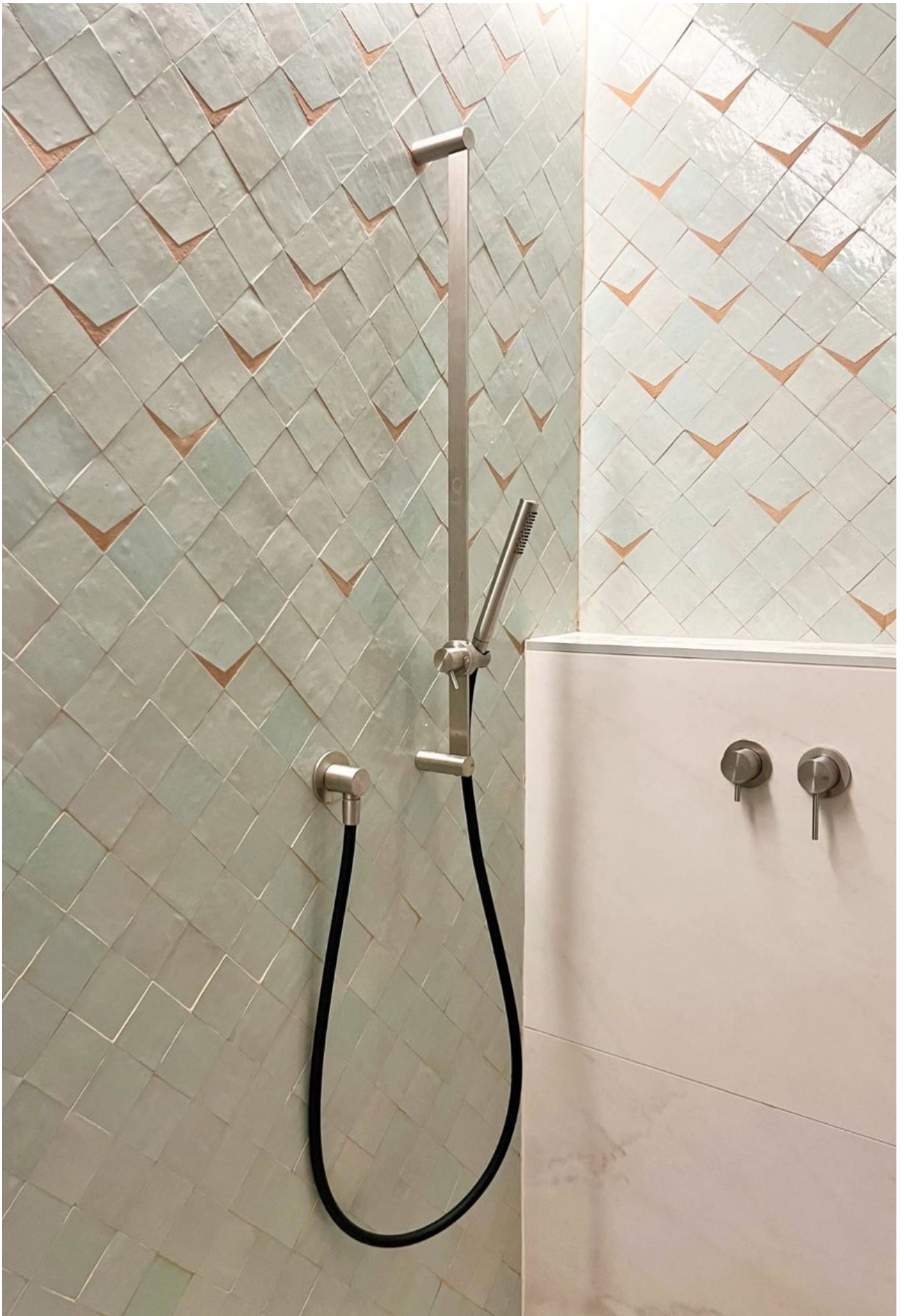

TATAOUI 01

Tataoui is named after the technique it uses. The interlacing lines engraved on the enamelled zellige reveal the raw material. This reinterpretation of traditional Tataouis drawings reveals a very graphic and contemporary composition.

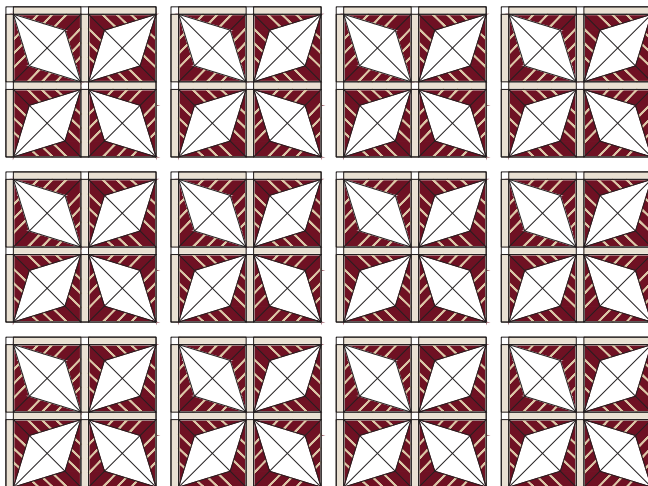
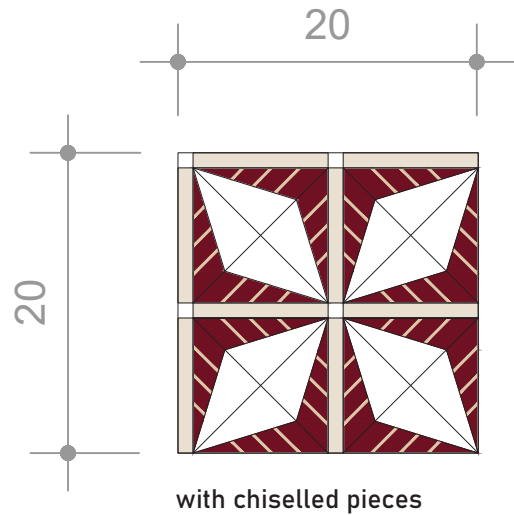
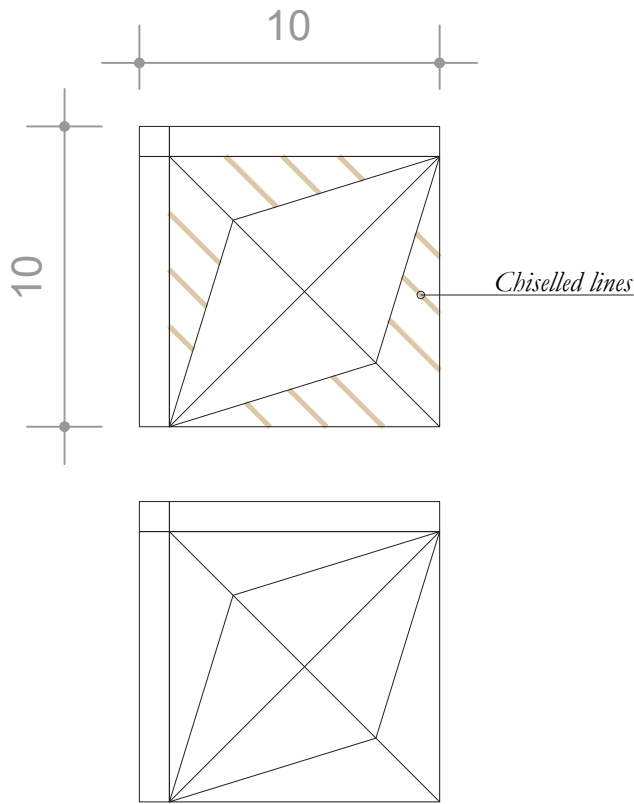

Pre-assembled and sealed plates

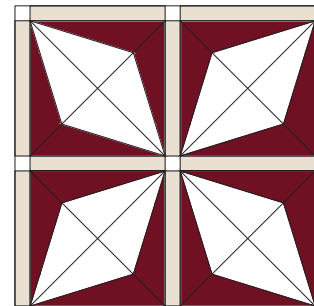

without chiselled pieces - Tataoui-02

Suitability	walls, kitchen, bathroom, shower... without chiselled pieces : floors
Size plate	≈ 20x20cm 7.8x7.8"
Thickness	12-14 mm 1/2 inch approx.
Number of pieces / sqm	1089/m ² 101/sqft approx.
Number of plates / sqm	25/m ² 1=0.43sqft
Colors	Colors chart









Couvent des Minimes Hôtel et Spa 5* - Deplanta architecte - Crédits photo : Think Utopia - Mane



Crédits photo: Francisco Nogueira - Beijmat Studio

TOUAREG

Touareg is inspired from the tents of the Tuaregs in the desert. This decoration consists of intertwined open and closed tents in sand tones. This graphic and timeless composition to highlight your living room, a fireplace, or even an exterior.

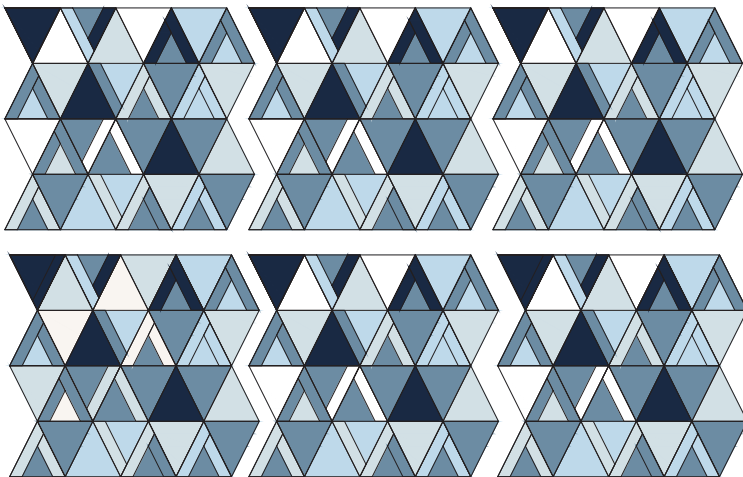
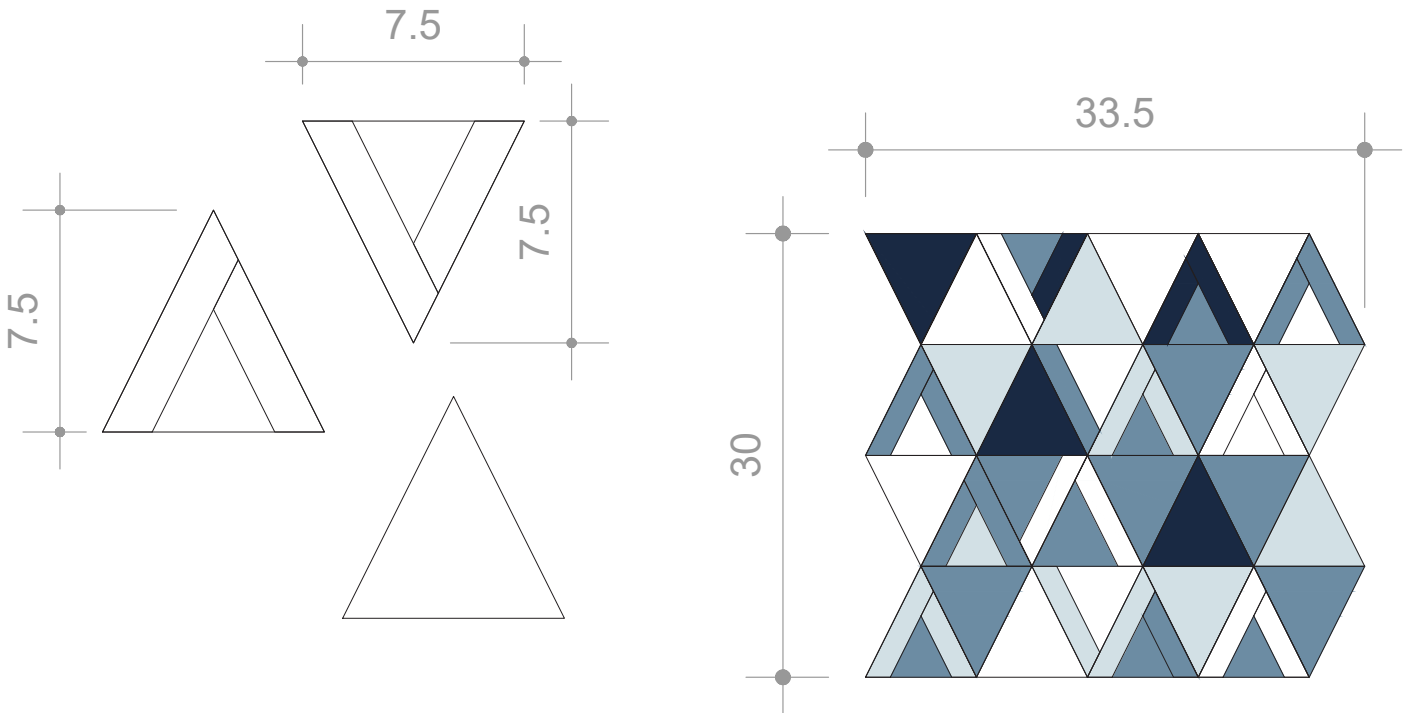

Pre-assembled and sealed plates

- Suitability** walls, kitchen, bathroom, shower...
- Size plate** $\approx 33.5 \times 30 \text{ cm}$ | 13.2x11"
- Thickness** 12-14 mm | 1/2 inch approx.
- Number of pieces / sqm** 684/m² | 64/sqft approx.
- Number of plates / sqm** 12/m² | 1=0.9 sqft
- Colors** Colors chart



PARTICULE

Particule floating, light, aerial. Through the use of the marvellous know-how of chiselling, Salima Filali makes a few enamelled particles float in a decor that is both ethnic, graphic and timeless. An assembly re particles seem to be hanging over the decor. A both playful and poetic composition.

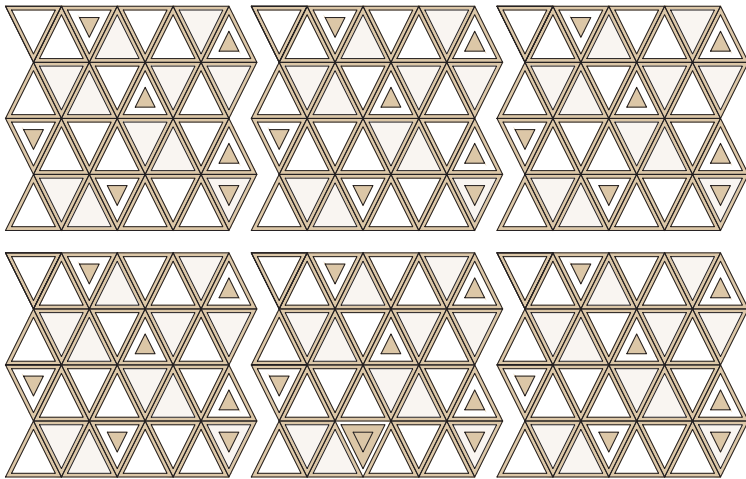
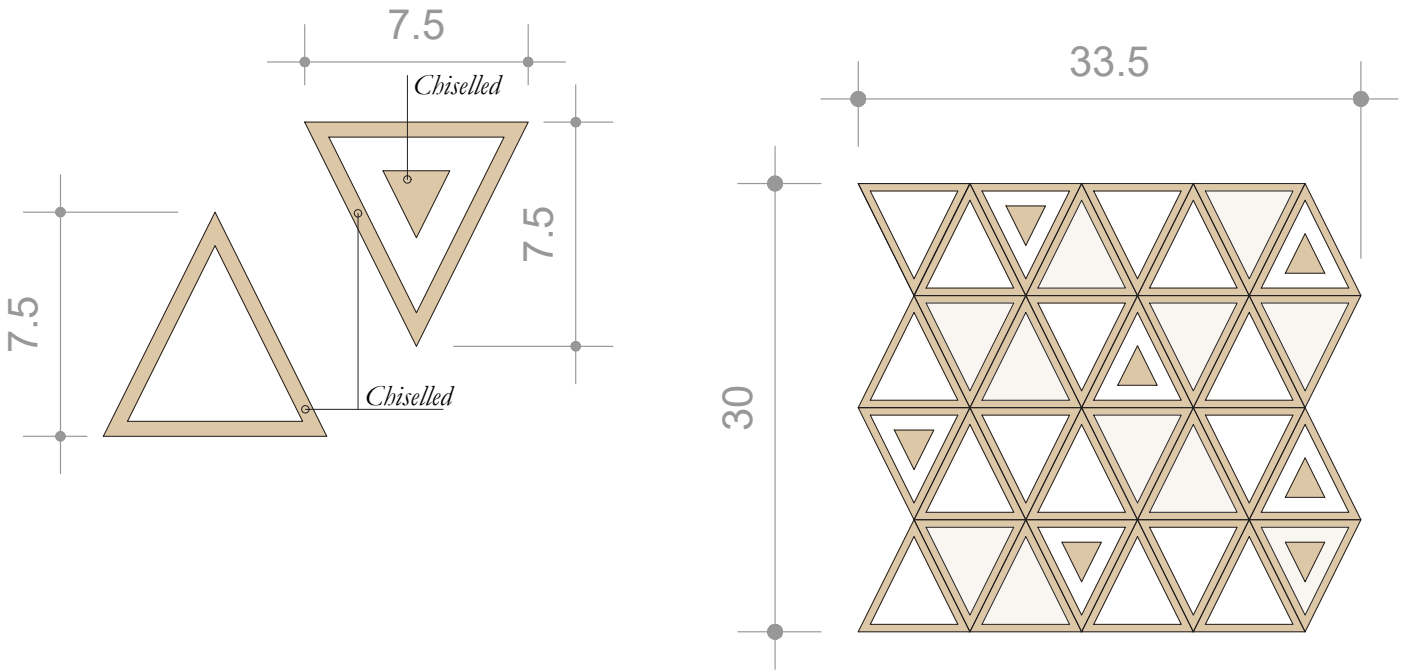

Pre-assembled and sealed plates

Suitability	walls, kitchen, bathroom, shower... without chiselled pieces: floors
Size plate	≈ 30x32.5cm 11x12.8"
Thickness	12-14 mm 1/2 inch approx.
Number of pieces / sqm	143/m ² 13/sqft approx.
Number of plates / sqm	14/m ² 1=0.77 sqft
Colors	Colors chart



AURORE

Aurore is a combination of rounded and chiseled shapes inspired by the sunrise at dawn. A soft and graphic landscape is formed in the repetition of geometric shapes.

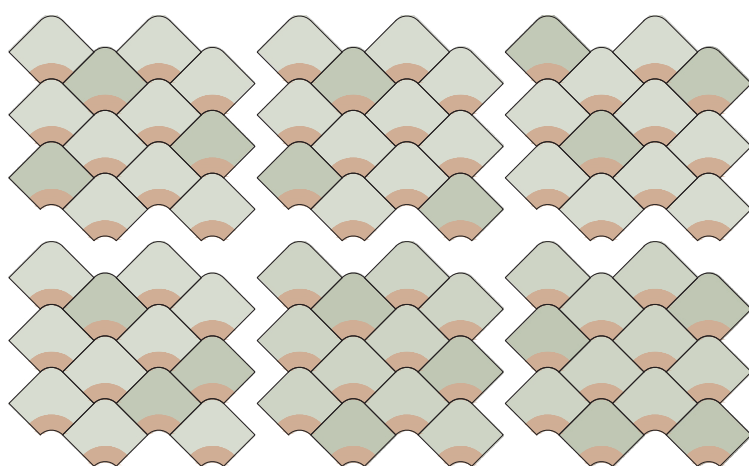
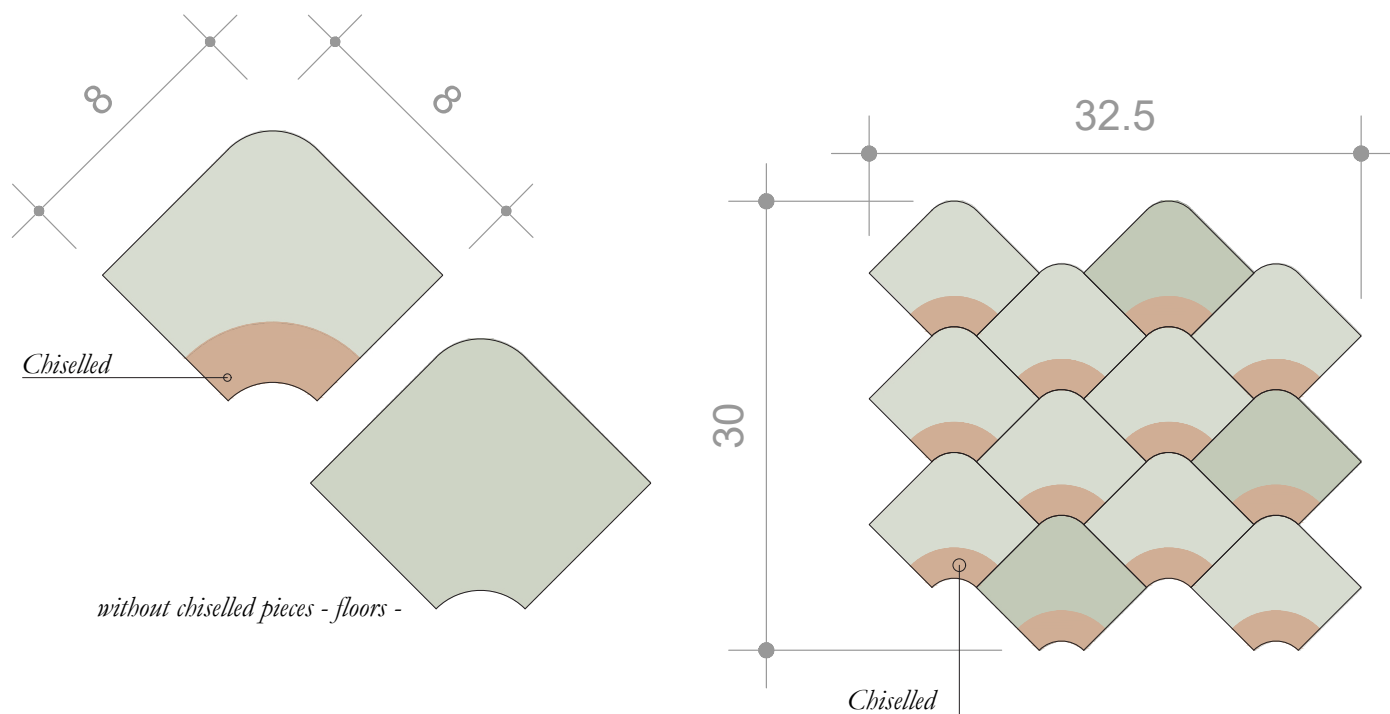

Pre-assembled and sealed plates

Suitability	walls, kitchen, bathroom, shower... without chiselled pieces : floors
Size plate	≈ 30x32.5cm 11x12.8"
Thickness	12-14 mm 1/2 inch approx.
Number of pieces / sqm	143/m ² 13/sqft approx.
Number of plates / sqm	14/m ² 1=0.77 sqft
Colors	Colors cahart



ECLAT 01

Like little flashes of light on the surface of the water at sunset. This tended to be both contemporary and feminine: pure lines punctuated by small bursts of gold.

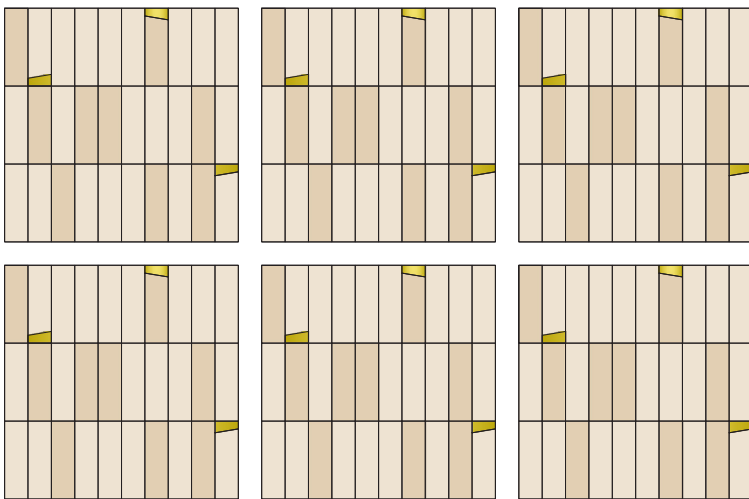
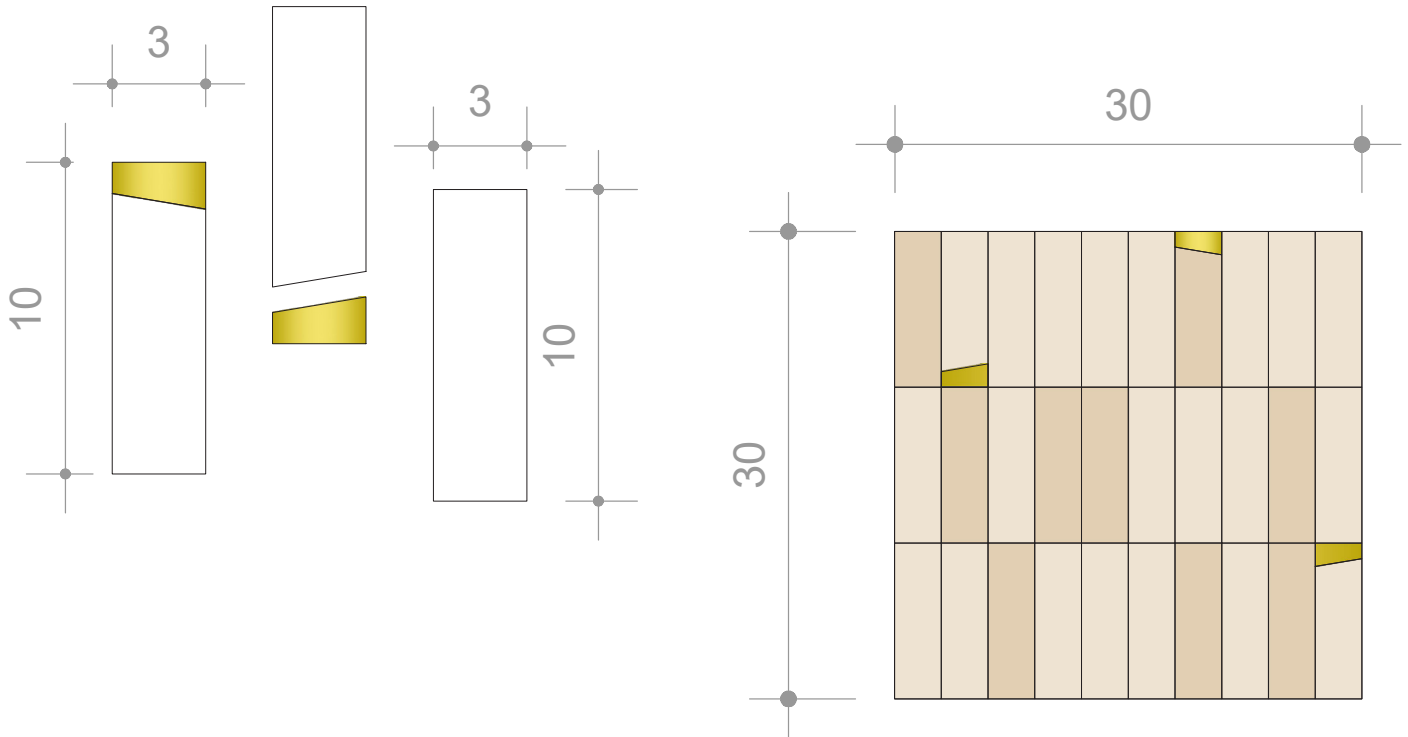

Pre-assembled and sealed plates

- Suitability walls, kitchen, bathroom, shower...
- Size plate ≈ 30x30cm | 11x11"
- Thickness 12-14 mm | 1/2 inch approx.
- Number of pieces / sqm 363/m² | 33/sqft approx.
- Number of plates / sqm 11/m² | 1/sqft
- Colors Colors chart



DUNE

Dune is an assembly of shapes inspired by the dunes of the Sahara at sunset. One half of the dune is always illuminated and the other in shadow. This play of shadow and light has been reinterpreted in this creation of zelliges.

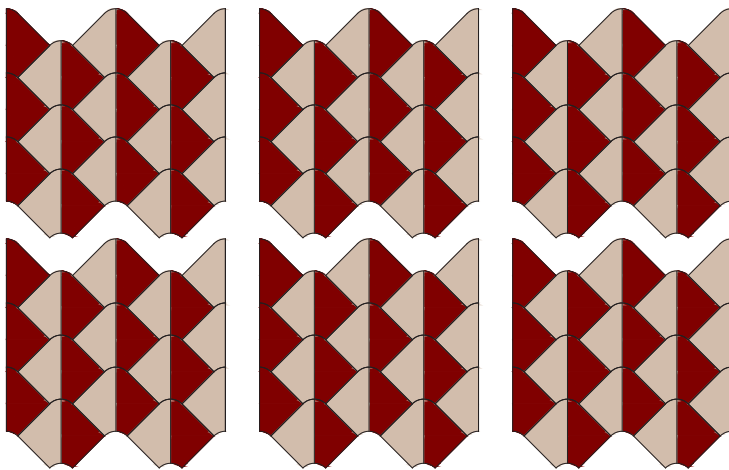
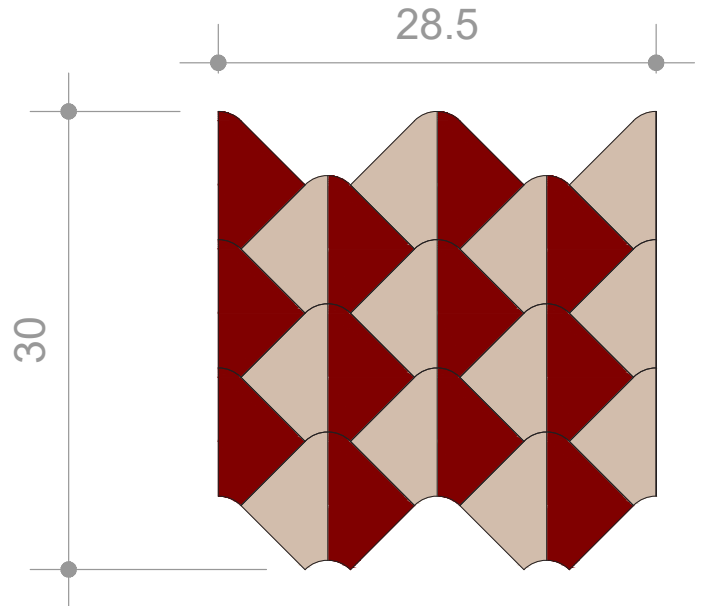
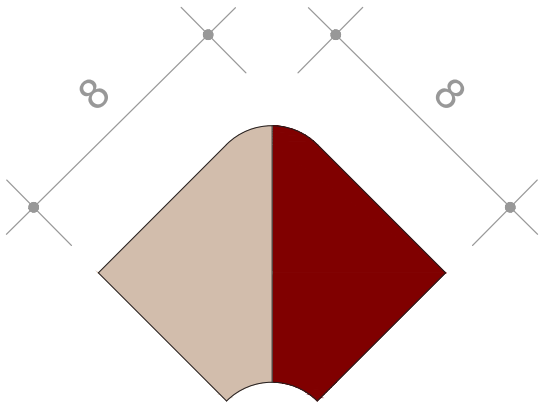

Pre-assembled and sealed plates

Suitability	walls, floors, kitchen, bathroom, shower, ..
Size plate	≈ 28.5x30cm 11x11"
Thickness	12-14 mm 1/2 inch approx.
Number of pieces / sqm	286/m ² 20/sqft approx.
Number of plates / sqm	14/m ² 1=0.77 sqft
Colors	Colors chart



ZAHRA

Zahra meaning "flower" in Arabic, is a reinterpretation of the famous assembly of squares punctuated with "cabochons" in a new language that is both feminine and delicate.

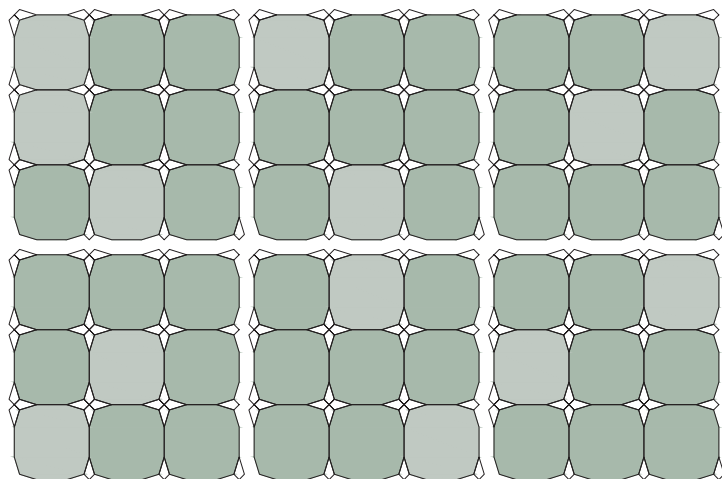
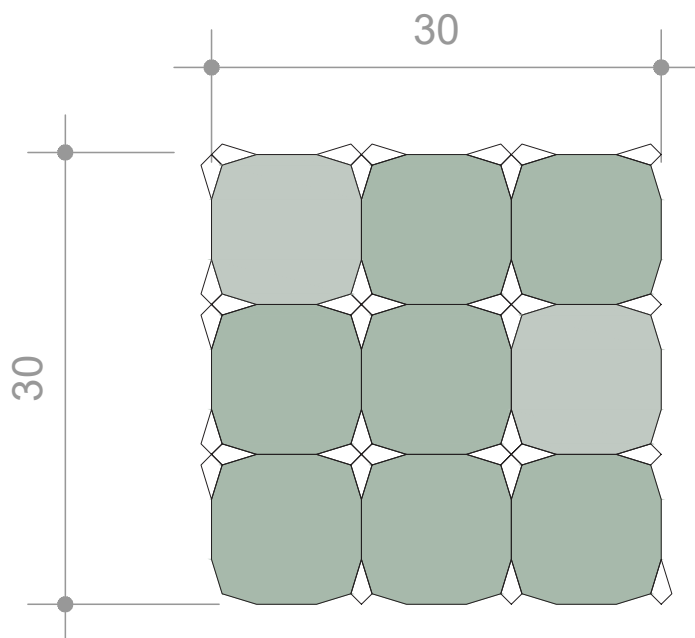
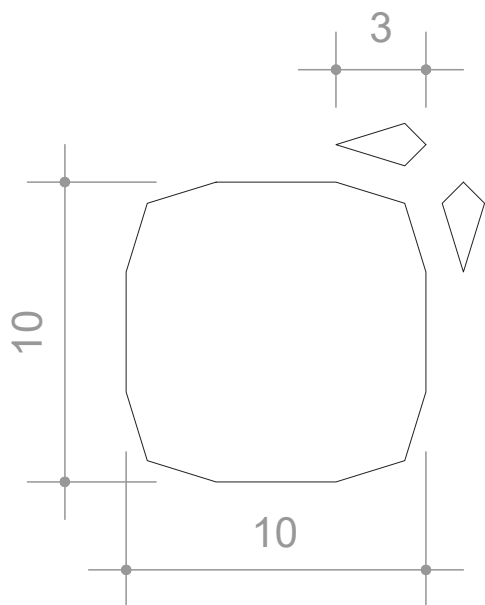

Pre-assembled and sealed plates

Suitability .. walls, floors, kitchen, bathroom, shower ..	
Size plate	~ 30x30cm 11x11"
Thickness	12-14 mm 1/2 inch approx.
Number of pieces / sqm	495/m ² 45/sqft approx.
Number of plates / sqm	11/m ² 1/sqft
Colors	Colors chart



CLASSICS COLLECTION

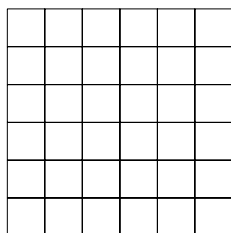

SQUARE 5x5
walls - floors

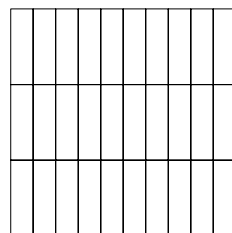

RECT. 3x10
walls - floors

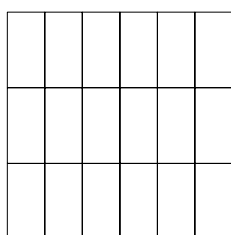

RECT. 5x10
walls - floors

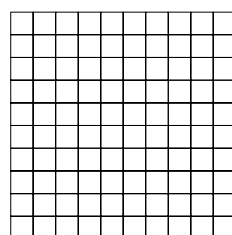

SQUARE 3x3
walls - floors

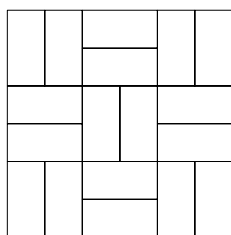

RECT. 5x10
walls - floors

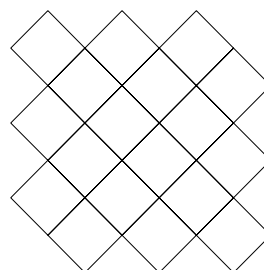

SQUARE 7x7
walls - floors

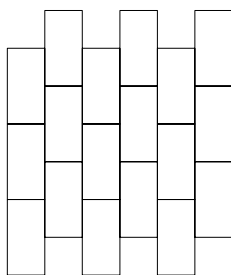

RECT. 5x10
walls - floors



BEJMATS 5x15
walls - floors

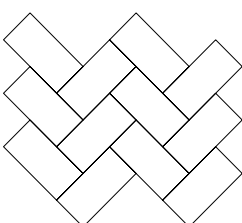

RECT. 5x10
walls - floors



SQUARES 10x10
walls - floors



ARTWORK

ZAGORA

Inspired by the delicacy and simplicity of Berber motifs from southern Morocco, the Zagora creation imitates a play of solids and voids, shadows and light, which can be found on adobe facades. Sublimated by shades of white, Zagora is presented in a three-dimensionality highlighting the details and the work of each manually cut piece.

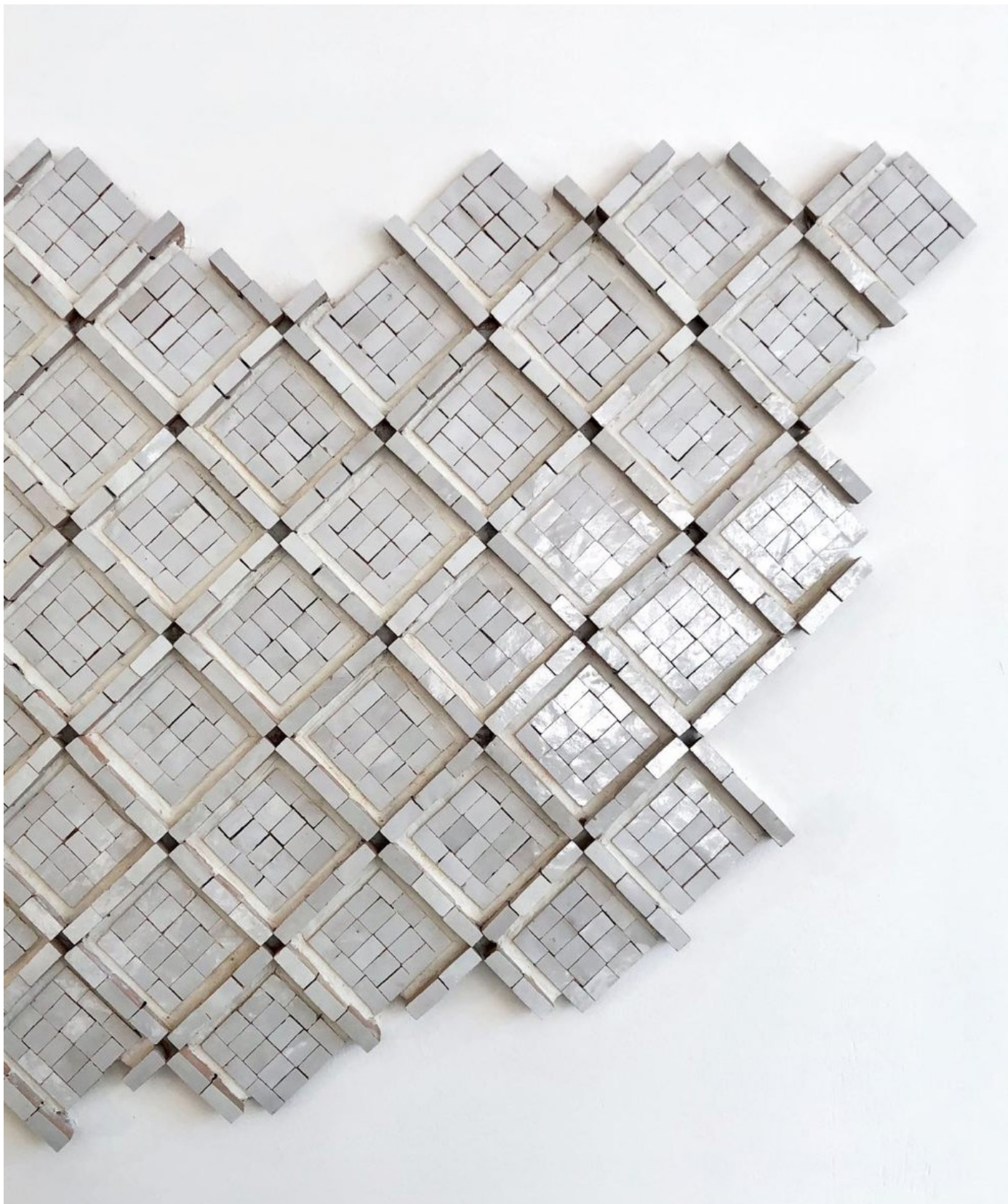

ARTWORK

MUQUARNAS

This creation is inspired by the sculpted pattern in the shape of honeycombs, known as the *Muquarnas* in the Middle East. A know-how of incredible technical complexity revealing a work of sculpture of full and empty. *Muquarnas* translates into a new language of textures, shadows and light allowing to reveal a landscape in a three-dimensional vocabulary.



COLORS

A possible variation of shades is one of the characteristics of zellig . The zelliges can present variations from one cooking to the other. In each color there are also variations of shades from one piece to another.

Please note that the colors you perceive on the screen may be slightly reality.

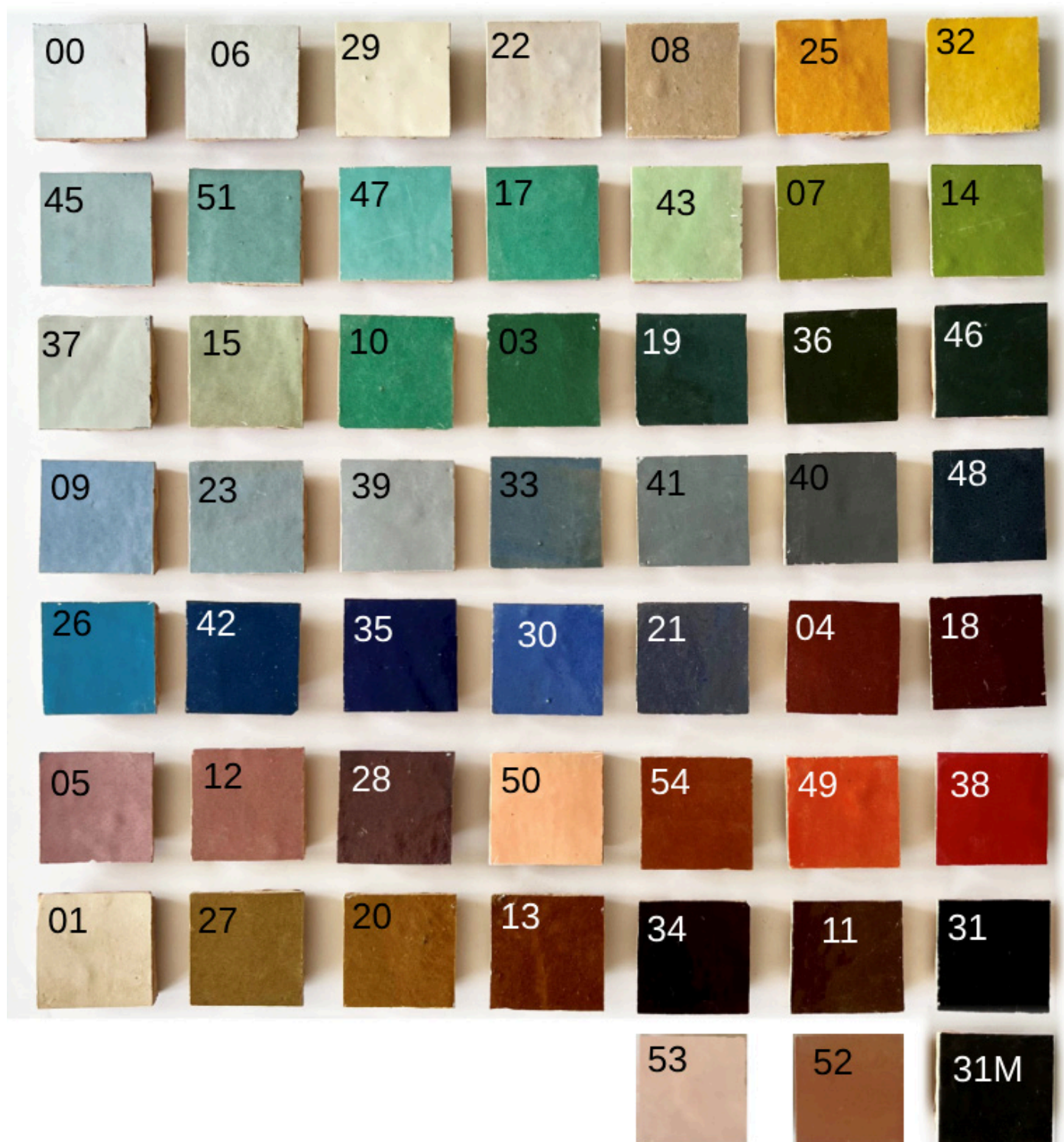

* Other colors are available on request.





www.salimafilali.com
contact@salimafilali.com
 [@salimafilalidesign](https://www.instagram.com/salimafilalidesign)

COPYRIGHT AND MARKET

All contents of the pages of this catalogue, as well as of the website (images, logos, photographs, copies, drawings and other documents) are the private property of Salima Filali.

For more information on the collection, the Terms and Conditions, please visit the website: www.salimafilali.com

This document is intended to provide an overview of the collection of zelliges coatings and decorations created by Salima Filali.

Crédits photographiques ©Salima Filali, ©Céline michel, ©Luca Fascini.

